

Relationship between Cultural Intelligence and Symbolic Capital: A Case Study from Faculty Members of Sistan and Baluchestan University

Zahra Vazifeh¹ and Ehsan Namdar Joyami^{2*}

¹Department of Management, University of Sistan and Baluchestan, Iran.

²Public Administration (HRM), University of Sistan and Baluchestan, Iran.

ABSTRACT

This paper aims to study the relationship between cultural intelligence and symbolic capital. One main hypothesis and three sub-hypotheses were raised in order to study the relationship between cultural intelligence and symbolic capital. Values and directions of the hypotheses for cultural intelligence with symbolic capital (economic-cultural-social) were 0.64, 0.61, 0.75 and 0.69, respectively. Statistical population of this research comprised of faculty members of Sistan and Baluchestan State University which is 274 members. Multistage cluster sampling was used in this research. Meanwhile, the sample size is 159 which is determined by using Kerjesi-Morgan table and Cochran formula. SPSS 21 and LISREL software were used in this research for the statistical analysis. The higher cultural intelligence of people and the higher adherence to native culture and values accept symbolic capitals based on their culture and values and respect these ideas and symbols. Therefore, one who has this type of capital has the respect of other people.

Keywords: Cultural Intelligence, Economic Symbolic Capital, Social Symbolic Capital, Cultural Symbolic Capital.

1. INTRODUCTION AND STATEMENT OF THE PROBLEM

Man is a transcendent being who is always looking for perfection and pursues dignity and social relations. While looking for perfection, ones follow a symbol (anything and anyone), while having respect and dignity for the symbol and tries to become close and behave similar to it in speaking, thinking and behavior. Organizations are formations consisting of people which sets the economic, social and cultural capitals. The center of gravity of the capitals is known as symbolic capital. In other words, the way people think, talk and act fits their symbolic capital and hence, goals are selected according to those symbols and symbolic capitals (Namdar, 2015). Symbolic capital has three symbolic dimensions which is economic, social and cultural dimensions that can be examined in two aspects, including the variable of symbolic capital based on Iranian-Islamic model and the variable of symbolic capital based on Western model (Namdar, 2015).

In the first case, the ethical and religious symbols of individuals are studied. The ethical and religious symbols of individuals refer to the individual's values, thoughts, beliefs and paradigms of thought (methodology-ontology and epistemology) in theory (Symbolic Capital of Namdr Joyami). In the second case, the paradigms of thought, values and beliefs of a person in terms of material immoral symbols are considered. In this study, ethical symbolic capital was considered based on the Iranian-Islamic model, or symbolic capital based on ethics and religion.

* Corresponding Author: davood.joyame@gmail.com

Among individual factors, cultural intelligence is one of the factors that attract researchers' interest. Cultural intelligence provides a suitable ground for employees in order to understand what their coworkers think and act. Cultural intelligence, by reducing communication barriers, increases voluntary cooperation among employees during the time. In addition, by creating the suitable ground for the emergence of positive behaviors based on the symbolic capitals among the employees; increases the effectiveness of organization (Namdar, 2015). Therefore, it is expected that people with higher cultural intelligence, have symbolic capital based on the Iranian-Islamic model because people understand their coworkers and have better interaction with other social and cultural groups and these behaviors are in line with symbolic capitals based on the Iranian-Islamic model. Therefore, this research aims to study the relationship between cultural intelligence with symbolic capital (A case study from faculty members of Sistan and Baluchestan University).

The community has been selected by the faculty members of the University of Sistan and Baluchestan. They play a significant role in the production and reproduction of various types of economic, social and cultural assets, and can institutionalize it among students, staff members, and faculty members.

2. LITERATURE REVIEW

Hazrati (2014) conducted a research titled "Sociological study of the relationship between symbolic capital and attitude to civil rights (Case study: Tabriz) " as a fulfillment for her master's degree. The sample of the study consist of 400 people over 15 years of urban areas in the city of Tabriz. The results indicate a relationship between symbolic capital and approach to civil rights and also a significant relationship symbolic capital with attitude to civil rights and attitude to social rights.

A research was conducted in 2012 by Abdollah ZadehMinaiee (2012) titled "The impact of family symbolic capital on domestic violence" in order to obtain a master's degree. In this study, the symbolic capital was evaluated according to Bourdieu's Theory. The population in the study include married women living in Tehran. The sample of the study consist of 385 subjects. The research tool used for this study was a researcher-made questionnaire and also 15 semi-structured interviews. The results showed that there is a significant positive correlation between symbolic capital (economic, social and cultural) and domestic violence, and with increased symbolic capital, the type of violence would change from physical to psychological and social.

Piri (2012) conducted a research titled "Study the role of symbolic interaction in the intimacy of couples from the perspective of women in the city of Karaj" as a fulfillment for her master's degree. This study is the result of interviews with 100 educated women living in the city of Karaj. The interviews were conducted by qualitative and content analysis method. The results indicated that consultation and informing the spouse on current affairs and personal tasks, and having a sincere and constructive dialogue generates intimacy between couples. These factors indicate the interest and attention of men to their wives. Finally, the Iranian families were recommended to use friendly and sincere dialogues with their wife in order to have a warmer and more intimate family.

A research was conducted in 2014 by Dana Gavereliuc et al. (2014) entitled as "Symbolic capital and cultural capital dimensions for Romanian educational organizations". This research was conducted in the western part of Romania. In this study, the symbolic capital is mentioned as the motor-generator creating open patterns in the learning environment. The researcher examined the intellectual and behavioral problems and dilemmas of Western Romania education system and provided intellectual and practical solutions. He suggested the symbolic

capital as a relational modernization theory to improve the national educational system, which is rooted in social attitudes and cultural history of the country.

A research was conducted in 2009 by Chad Nilep entitled as "Interaction relatives and symbolic capital: Toward a political microeconomic theory". In this study, the researcher pointed out that the bigger siblings of an individual have the highest role in the socialization of the individual and sending him to the community. However, to keep power hierarchy in the family and dominance over others, older siblings may cause move toward dominance over other brothers and sisters. With this example, the researcher extends the discussion to the macro level of the society in larger scale, referring to the symbolic capital and political power, which may be created due to differences in language, culture, and society. Then, he suggested the analysts maintain the relationship between social structures and spread the face to face interaction structure within the community.

2.1 Symbolic Capital

The concept of symbolic capital is the most important part of Bourdieu work in the theory of symbolic power. Defining the concept, he says *"In calling every type of capital (economic, social and cultural) symbolic capital if is perceived from understanding categories, which depend on the principles of insight and division to classification systems and the cognitive formats that are partially the products of internalizing of relevant objective structures, namely, the capital distribution structures in the field (Bourdieu, 2006: 155)"*.

Every type of capital (economic - socio-cultural) serves as symbolic capital on varying degrees. Bourdieu gets help from Weber's charismatic and legitimacy concepts to expand the concept of symbolic capital. In fact, one may say that the most important influence of Weber on Bourdieu would appear here. As Weber, Bourdieu believes that the exercise of power needs legitimacy. According to Bourdieu, individuals, and groups capable of changing themselves from groups and individuals with certain interests to groups and individuals with no interests have been succeeded to achieve symbolic capital (Swartz, 2007: 3; Hazrati, 2014).

Symbolic capital is somehow the denied capital. This capital hides the relationships based on fundamental interests concerned with them through legitimating them. Then, the symbolic capital is a form of power that is seen not as power but as a legitimate demand for recognition, respect, obedience, and service to others (Swartz, 2007: 27; Hazrati, 2014). Thus, the symbolic capital can be somehow called legitimate capital; since the symbolic capital defines what forms and uses of capital would provide on a legitimate basis for social positions of individuals in a society. The efficiency of symbolic capital is dependent on the actual performance of communications.

The issue of raising symbolic capital justifies how a lot of people initially who had a normal capacity and talent could achieve a great power status by occurring in good social conditions and with the help of lateral factors such as mass suites crisis and benefit from scientific and artistic competence. Symbolic uses vary in terms of social classes and strata and depend on the social environment in which one lives, i.e., the volume of symbolic capital available to any class and the cultural criteria by which any class defines itself. In this regard, the ruling class is seeking to maintain its position through differentiation and detection strategy and wants to impose its will on the rest of the society and groups. This is why as soon as the social capital or cultural capital becomes general and pandemic and known for all, it will be replaced with a new social and cultural behavior belonging to the ruling class (Bourdieu, 1985).

The logic of symbolic violence reveals the imposing meaning in the line of its arbitrary forgetting. Such culture and social relations is a subset of a more general collection called symbolic territory and products that helps to legitimize political, legal and religious areas. The

producers generate symbolic signs that are organized as different cultural systems. The organizing of these symbolic signs occurs in the form of different social and cultural systems and according to social and class struggles, and therefore, the class struggle is manifested as a symbolic struggle (Bourdieu, 1985; Piri, 2012).

With regard to the cases stated in the literature, it must be suggested that symbolic capital is primarily considered as a transformation of any type of asset or capital being seen as a symbol, and its owner will be respected and honored by people, and somehow is seen as prestige. In addition, it is any type of capital seen as a symbol in the eyes of others. In other words, symbolic capital is a distinct aspect of any investment and capital and should be considered as a dimension of any capital.

In the first case, symbolic capital can be considered as a variable separate from other capitals and as the fourth capital. In the second case, symbolic capital can be considered as one dimension of any capital. In the following, each of the symbolic capital dimensions was discussed:

2.2 Economic Symbolic Capital

According to the stated content, one can say that the economic symbolic capital includes those group of economic capitals accepted by the community as a symbol and their owner is respected and honored by people.

Economic symbolic capital is any tangible asset and capital that its owner can quickly convert it into cash. However, it should be noted that economic symbolic capital does not mean having more economic capital, and sometimes the opposite is true. In some regions and among certain people, simple life and living simply without luxuries may be valued and respected as economic symbolic capital. But in general, it must be stated that economic symbolic capital is considered as any kind of economic capital used as a symbol and prestige, and its owner is respected by people (Namdar, 2015).

2.3 Cultural Symbolic Capital

Cultural symbolic capital includes those cultural capitals considered as a symbol for the people, and people respect their owners particularly (Symbolic cultural capital is some kind of cultural capital that its owner is respected in the eyes of people). However, it should be noted that the symbolic cultural capital does not mean having more cultural capital, and sometimes the opposite is true. Thus, in certain areas and among certain people, a certain culture or wholly negative culture contradictory to the accepted culture may be valued and respected as symbolic cultural capital) (Namdar, 2015).

But in general, it must be stated that the symbolic cultural capital is considered any kind of cultural capital used as symbol and prestige, and its owner is respected by the people (a certain group).

In the end, some are given for better understanding of symbolic capital and symbolic capital dimensions, which we do hope would be fruitful for researchers in understanding and approaching the true sense of this type of capital.

2.4 Social Symbolic Capital

Social symbolic capital includes those social capitals that are highly respected and valued among people and considered as a symbol by the community (such as membership, cooperation, and communication with individuals and groups that are considered as a symbol by people and

associated with dignity and respect for those individuals) (Namdar, 2015). However, it should be noted that social symbolic capital does not mean having more social capital, and sometimes the opposite is true. Thus, in some regions and among certain people, a simple and non-busy life may be valued and respected as social symbolic capital. But in general, it must be stated that social symbolic capital is any type of social capital used as symbol and prestige and its owner is respected by people (Piri, 2012).

2.5 Cultural Intelligence

There are various definitions and classifications for cultural intelligence and its dimensions. However, this research only considered related definition and classification of Erli and Aveng (2003) for cultural intelligence and its dimensions. These two researchers believe that the ability for learning new models in cultural interactions and providing correct answers to these models consists of four dimensions which is metacognitive, cognitive, motivational and behavioral dimension.

- i. **Metacognitive dimension:** in this method, an individual reasons for intercultural experiences and considers the process which people use for understanding and obtaining cultural knowledge. Metacognitive dimension can be divided into two complementary elements which is metacognitive knowledge and metacognitive experience. Metacognitive knowledge means how to integrate related experiences as interactions guides for future. Meanwhile, metacognitive dimension is a sensitive and important aspect of cultural intelligence (Early and Peterson, 2004).
- ii. **Cognitive dimension:** this dimension of cultural intelligence relates to the cognition of an individual from similarities and differences in the cultures which reflects general knowledge about cultures like information about beliefs, religious and spiritual beliefs, values and beliefs about work, time, family relations, customs, values, norms, and language (Namdar, 2015).
- iii. **Motivational dimension:** this dimension indicates trust and confidence of people that whether he can adjust himself with a new culture. Does he has great motivation for recognizing new culture? This dimension indicates the amount and direction of energy for effective interaction in a new culture and it includes a level in which individuals are confident about their abilities in intercultural interactions and also high exposure for a good experience in the interaction with people of other culture. Besides that, they are highly satisfied from their interactions. Those who have higher motivation in the cultural intelligence, act more effectively in the inter-cultural interactions and have strong feeling that they can get along with different thoughts and varied and unknown conditions and manage complexity and non-confidence. However, when an individual has low cultural intelligence in motivation dimension, during achieving a goal, becomes disappointed, his efficiency decreases and gets a negative picture of himself and become isolated (Earley and Peterson, 2004).
- iv. **Behavioral dimension:** this dimension shows the capability for displaying verbal and non-verbal acts in interaction with people from different cultures and focuses that how people act in new cultural conditions and in fact, it refers to the ability of an individual in suitable reaction to the new cultural situation. Figure 1 shows the cultural intelligence dimensions:



Figure 1. Cultural intelligence dimension.

2.6 Main Hypothesis

There is a significant relationship between cultural intelligence and symbolic capital.

2.7 Sub-Hypotheses

- i. There is a significant relationship between cultural intelligence and economic symbolic capital.
- ii. There is a significant relationship between cultural intelligence and cultural symbolic capital.
- iii. There is a significant relationship between cultural intelligence and social symbolic capital.

3. RESEARCH METHODOLOGY

Table 1 Methodology general framework

Research orientation	Applied
Research Philosophy	Positivism
Research Approach	Comparative
Research Strategy	Surveying
Method	Quantitative
Research tool	Questionnaire
Data Collection Method	Library – In Field

Statistical population of this research is about 274 comprising faculty members of Sistan and Baluchestan State University. Multistage cluster sampling was used. The sample size was 159 by using Kerjesi-Morgan table and Cochran formula, hence, the sample size of 170 was considered. The error factor of this research is 0.05. Software used in this study are SPSS 21 and LISREL 9.1. It is worthy to mention that the questions in the questionnaire were based on the Likert five-point scale. Face validity of the questionnaire was confirmed by experts (2 sociology assistant professors and 2 management assistant professors). Content validity was measured by confirmatory factor analysis. In this research, 5 questions were raised for each dimension of the independent and dependent variable.

Table 2 Cronbach alpha for variables and questionnaire using SPSS 21 software

Cronbach alpha	Cultural intelligence	Symbolic capital
Value	0.746	0.719

3.1 Research Conceptual Model

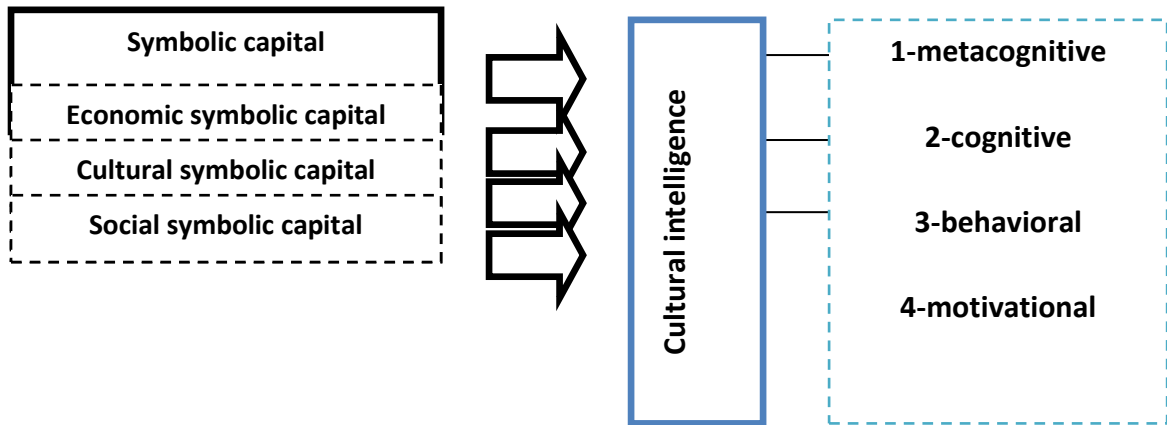

Figure 2. Research conceptual model.

3.2 Research Models for Structural Equations Modeling (LISREL 9.1)

Main model in standard estimation state:

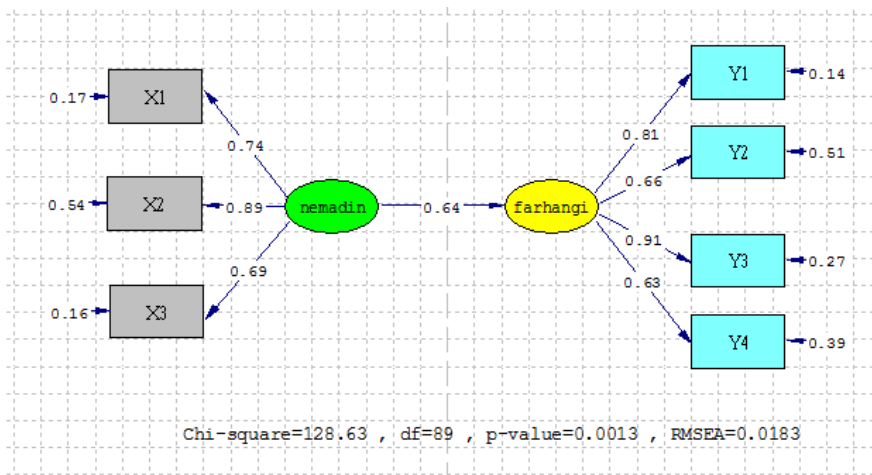

Figure 3. Main model in standard estimation state.

Main model in significance coefficient state:

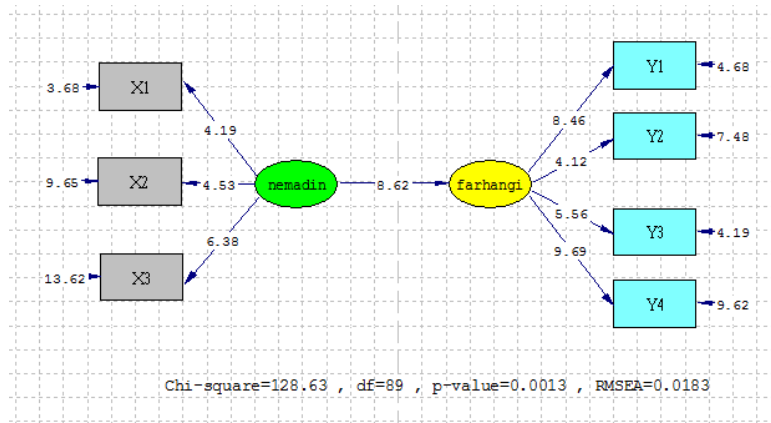

Figure 4. Main model in significance coefficient state.

Sub-model in standard estimation state:

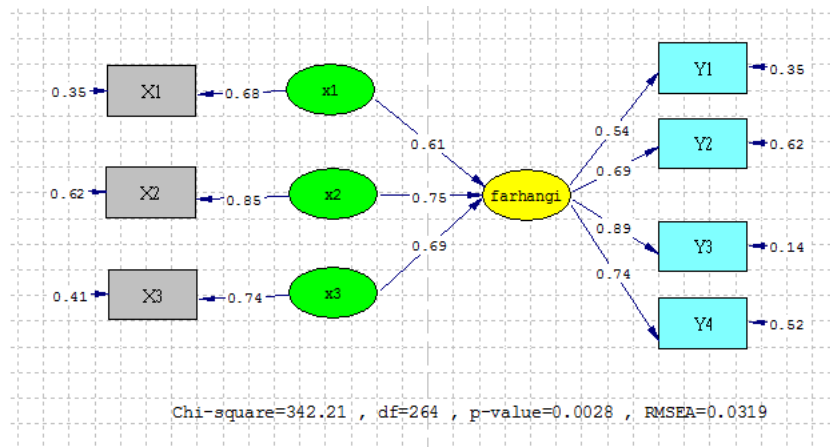

Figure 5. Sub-model in standard estimation state.

Sub-model in significance coefficient:

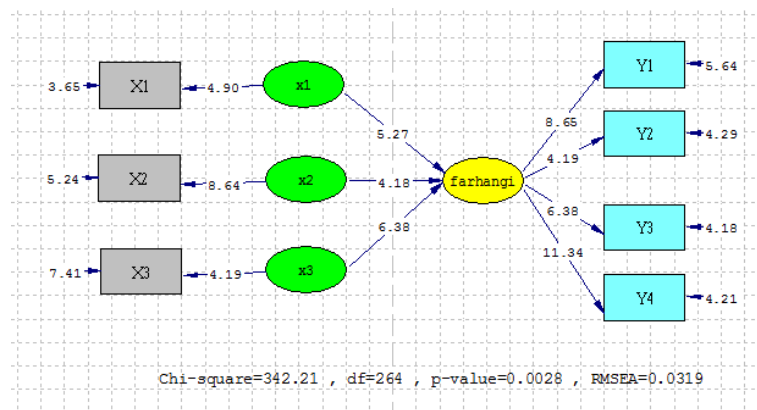

Figure 6. Sub-model in significance coefficient state.

4. RESEARCH FINDINGS AND EVALUATION OF THE RESEARCH HYPOTHESES USING THE PATH ANALYSIS APPROACH

In this section, we were seeking to prove the research hypotheses. We provided two models: 1) the research main hypothesis model, and 2) the sub-main hypotheses model. The table below 2 to the degree of freedom (df) smaller than 3, RMSEA smaller than 1 and GFI and AGFI greater than 90%, it can be concluded that the implemented model is properly fitted. If the value of *t* is larger than 1.96 or smaller than -1.96, the standard coefficient of the existing relationship would be significant at a confidence level of 99%.

Table 3 Structural equations model for the main hypothesis and sub-hypotheses

Structural equations model for research hypotheses			
Relationship (factor loading)			
	0.64		Main hypothesis
Fitness indices for the main hypothesis			
RMSEA	p-value	d.f	Chi-square
0.0183	0.0013	89	128.63
NFI	CFI	AGFI	GFI
0.94	0.92	0.92	0.95
Relationship (factor load)			
	0.61		Hypothesis 1
	0.75		Hypothesis 2
	0.69		Hypothesis 3
Fitness indices for sub-hypothesis			
RMSEA	p-value	d.f	Chi-square
0.0319	0.0028	264	342.63
NFI	CFI	AGFI	GFI
0.92	0.93	0.95	0.95

As can be seen, due to the significant value of *t*, the validity and appropriate fitness of the model is affirmed since the value of chi-square, RMSEA value, and the ratio of chi-square to the degrees of freedom are low, and the values of GFI and AGFI are higher than 90%.

5. DISCUSSION AND CONCLUSION

This research aims to study the relationship between cultural intelligence with symbolic capital. Therefore, one major hypothesis and three sub-hypotheses were confirmed. Direction and value of these hypotheses for cultural intelligence with symbolic capital (economic-cultural-social) was 0.64, 0.61, 0.75, and 0.69, respectively. In another word, we can say that if symbolic capital increases by one unit, cultural intelligence increases by 0.64 unit. Results indicate that by increasing the cultural intelligence, the symbolic capital increases. In other words, we should say that the higher the cultural intelligence of people and more adhere native culture and values, they accept more symbolic capitals based on the culture and values and respect the ideas and symbols. Therefore, the owner of this symbolic capital is respected by other people.

On the other hand, those who have higher cultural intelligence will have economic-cultural-social capitals based on the culture and therefore, act according to their economic, social and cultural dimensions.

In the world of constraints, everything faces with limitations and so does this research. This research is faced with the limitations of time and place as well. Therefore, the future researchers are suggested that to work on this topic in different times and places and compare their results with the results of this study. It is suggested that future researchers study variables of symbolic

capital variables and cultural intelligence in this research with other organizational and social variables and use in their research.

In other words, these people, by having ethical symbolic capitals based on the accepted cultural model, select their symbols and have different speech, behavior and thoughts corresponding to it and these speeches and behaviors originate from values and symbols accepted by them. Therefore, it is suggested to the social managers and authorities to promote symbolic capitals based on the culture of people in the organization and manage people by behavioral and verbal symbolic capitals inside and outside the organization.

Individuals have values that if they were not consistent with organizational values, this causes that people have paradox with organizational goals and follow their individual goals. Managers by managing this capital can align people with management goals and organization and by increasing symbolic capitals based on the organizational and social model, influence the cultural intelligence of people and increase symbolic capitals in the organization. In other words, people can have a more positive look to their environment and show respect in encountering with people to have motivation for achieving organizational goals.

We live in a world that has time and space constraints, and this research is not excluded, but given that these constraints are considered as part of any research and are an integral part of human research, they are ignored. Finally, it is suggested to other researchers to review this title in other organizations and compare their results with the results of this study, and it is suggested that the relevance of the variables used in this study were compared with other organizational variables.

REFERENCES

- Abdullah ZadehMinaiee, MG. (2012). *The influence of family symbolic capital on domestic violence, Master's thesis in Women and Family Studies*. AllamehTabatabaei University.
- Bourdieu, p. (2002). RI: <http://WWW.iran-emroozde/wored.001207>
- Bourdieu, Pierre. (2006). *A sketch of a theory of action, Translation by Mardiha*. Tehran: Naghsh o Negar Publication.
- Bourdieu, Pierre. (2006). *Forms of capital (social capital, trust, democracy and development*. Translation by Khakbaz and Pooyan, Tehran, Shirazeh Publication.
- Bourdieu,p. (1980). *Lesensepratique, paris, minuit, 88, 100-110*.
- Bourdieu,p. (1985). *Ladistingtion(critique social dujudment), les edition mimiut,Paris*.
- Earley, P.C. & Ang, S. (2003). *Cultural intelligence: individual interaction across cultural*s. Stanford, CA, Stanfords Business Books.
- Earley, P.C & Peterson, S. R. (2004). The Elusive Cultural Chameleon: Cultural Intelligence as a New Approach to Intercultural Training for the Global Manager. *Academy of Management Learning and Education, 3(1), 100-115*.
- Fakohi, N.. (2006). Pierre Bourdieu: Query on knowledge and enlightenment. *Journal of Social Sciences, Ferdowsi University of Mashhad, 2(1), 141-161*
- Gavereliuc, Dana; Gavereliuc, Alin. (2014). symbolic capital and cultural dimensions in Romanian educational organizations, *Procidia, social and behavior sciences, 127, 392- 395*.
- Hazrati, M. (2014). The Sociological study of the relationship between symbolic capital and attitude to civil rights (Case Study: Tabriz), Master's thesis in sociology, Islamic Azad University of Tabriz
- Namdarjoyami, E. (2015). Investigating the relationship between cultural capital, social capital and symbolic capital with consumer behavior in the garment industry (Case Study: Isfahan citizens), Master's thesis.
- Nilep, Chad. (2009). Sibling interaction and symbolic capital: toward a theory of political micro-economy, *Journal of Pragmatics, 41, September 1683- 1692*.

- Piri, M. (2012). Study the role of symbolic interaction in the intimacy of couples from the perspective of women in the city of Karaj, Family counseling psychology master's thesis, AllamehTabatabaei University.
- Shoyreh, Christine & Olivier Fontaine. (2007). *Bourdieu's words*, Translation by Katbi, Tehran, Ney Publishing.
- Sistan & Baluchestani, D. (2010). *Identifying factors affecting knowledge sharing in projects management*, Doctoral Dissertation, School of Management, Tehran University.
- Swartz, David. (2003). Political economy and symbolic power, Translation by Salehi, *Journal of Political Economy*, I, 3.

